

Tiny House 2

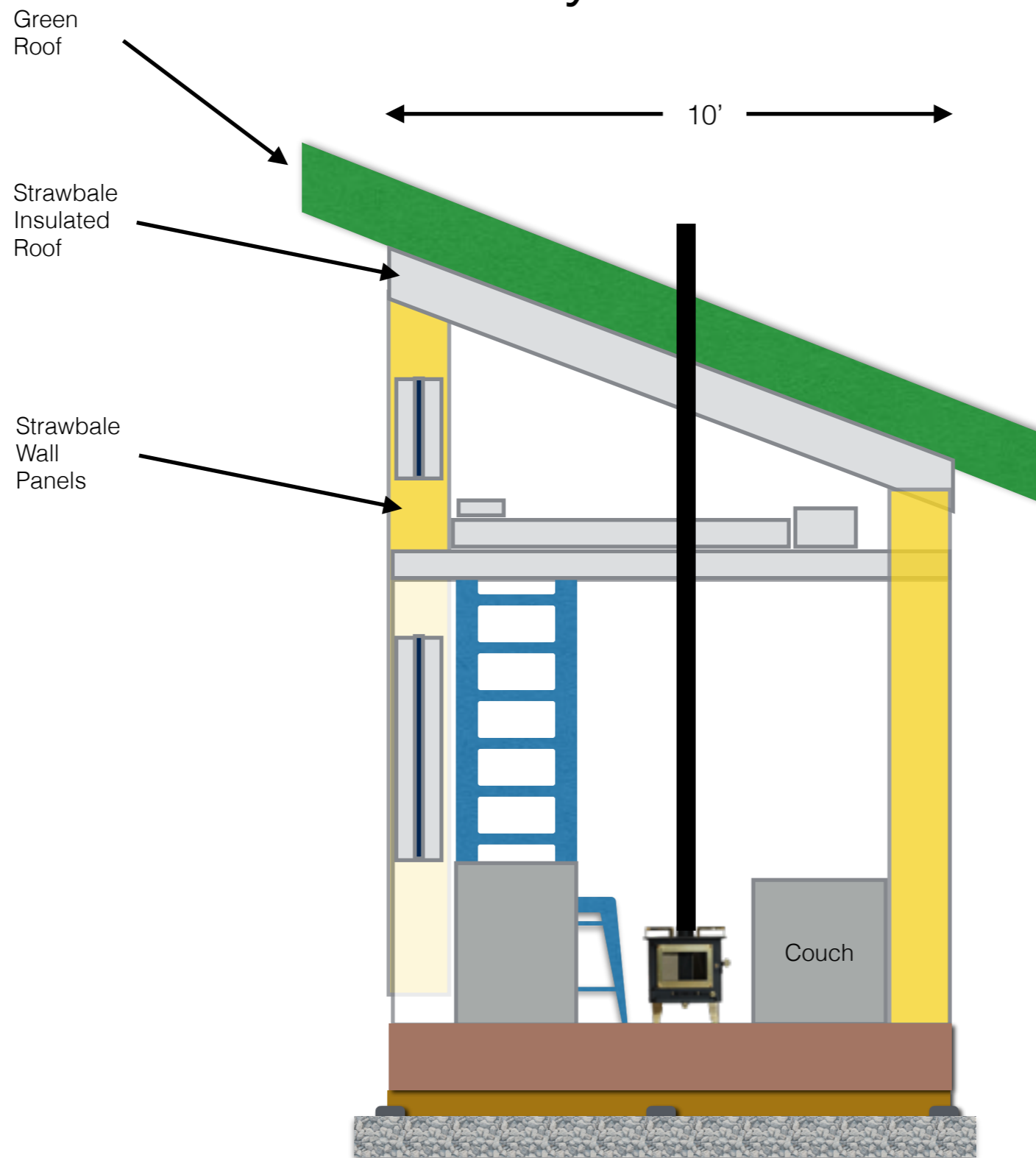

Side View

Plan View

Tiny House 2

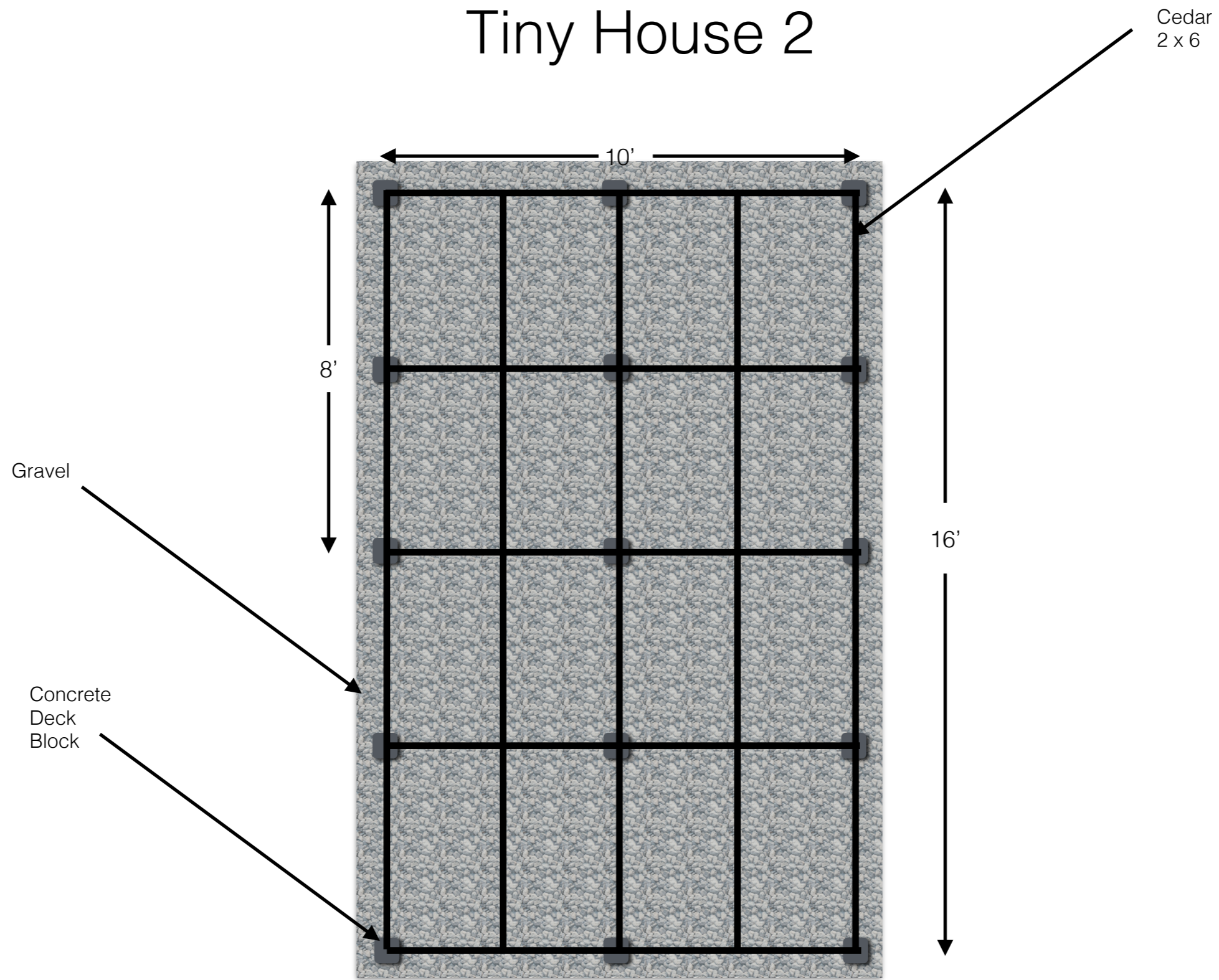

Deck Base
Plan View

Tiny House 2

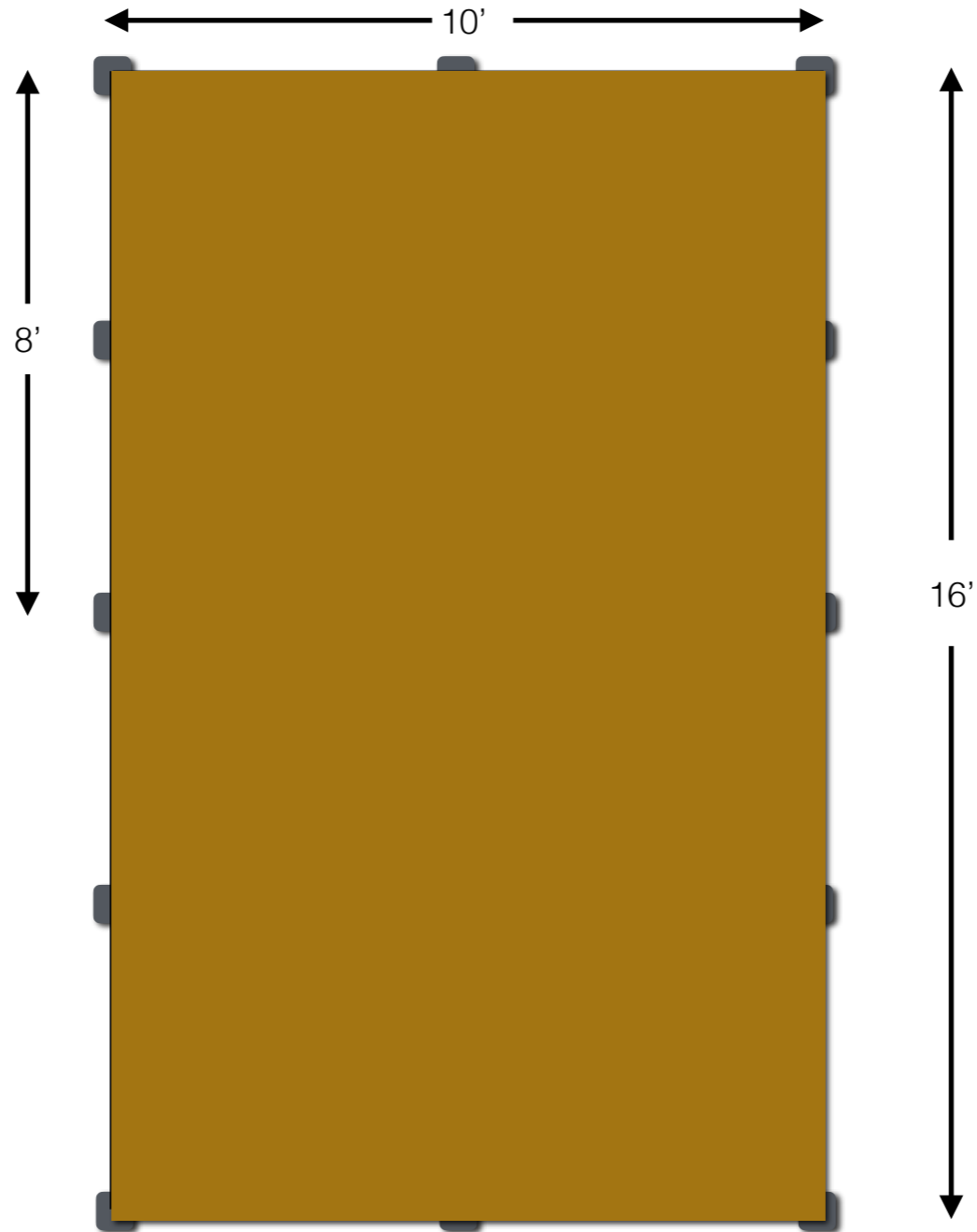

Deck Base with Plywood
Plan View

Tiny House 2

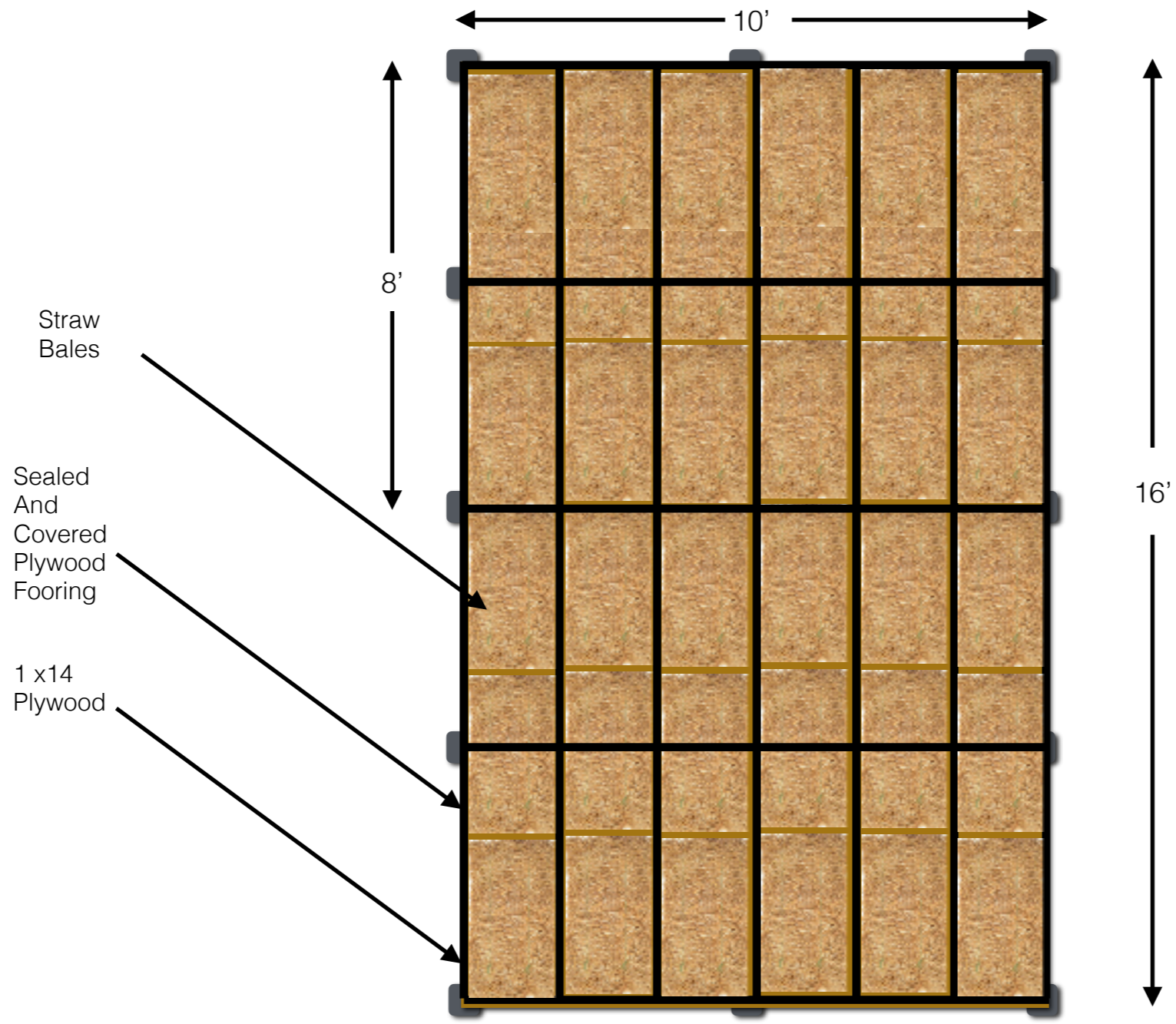

Floor and Strawbale Insulation
Plan View

Tiny House 2

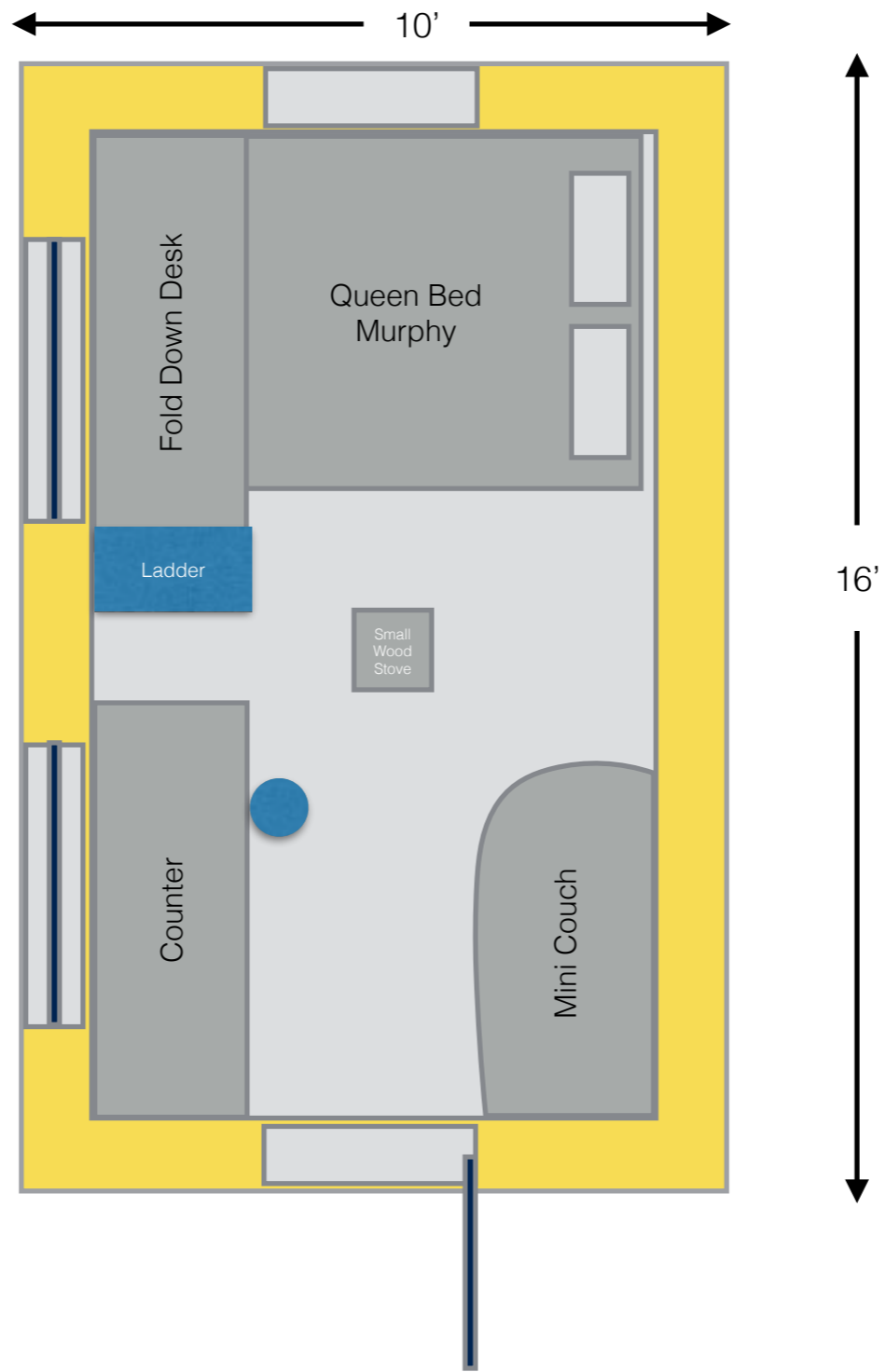

Plan View

Tiny House 2

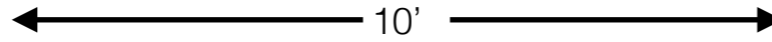

Plywood
Flooring
Over
Straw bale
Insulated
Base

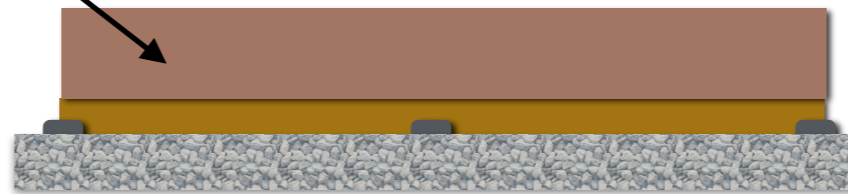
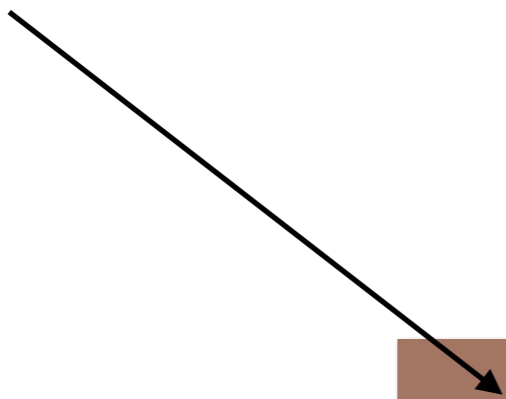

Floor and Strawbale Insulation
Side View

Tiny House 2

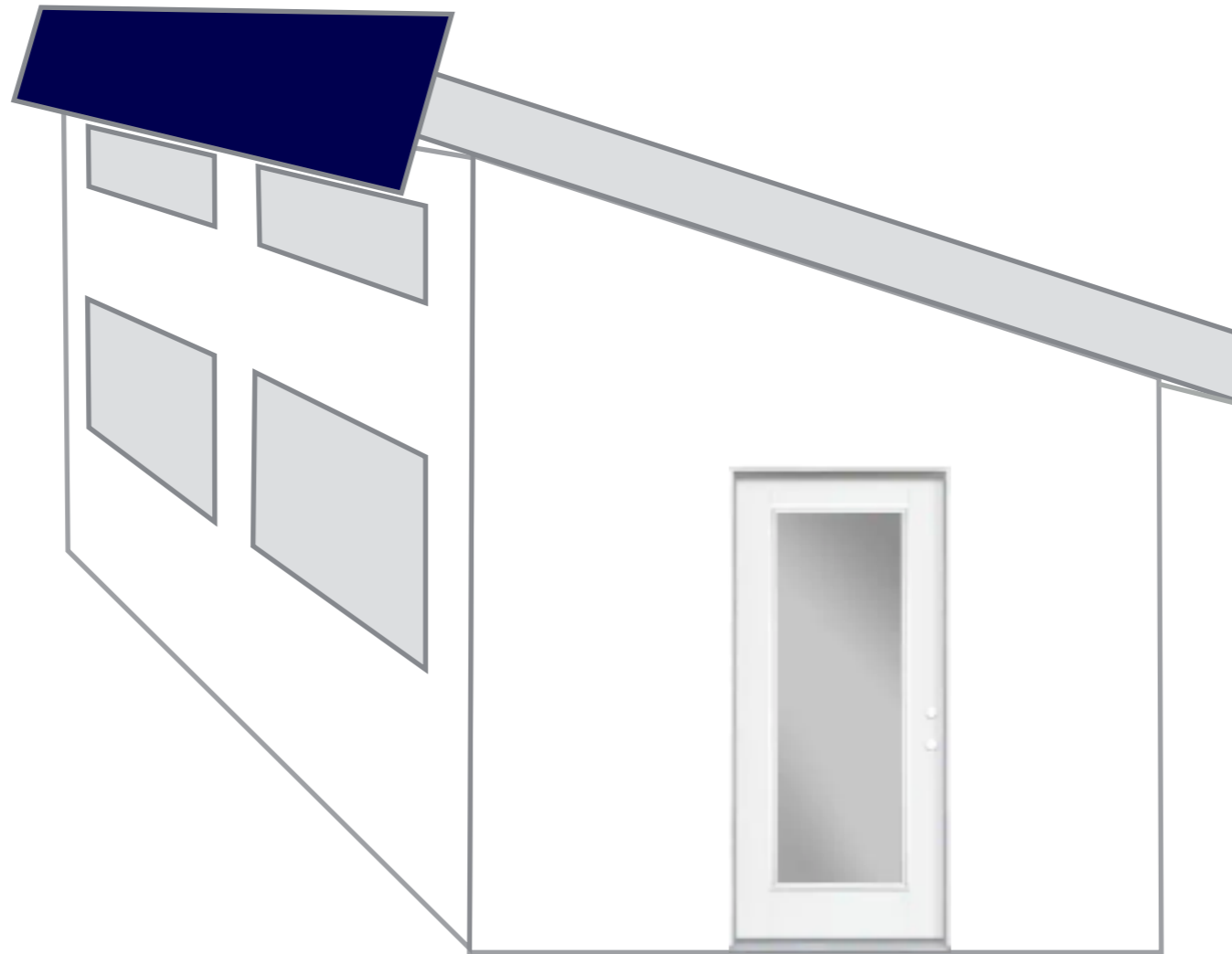

Modular Straw Bale Panel Design

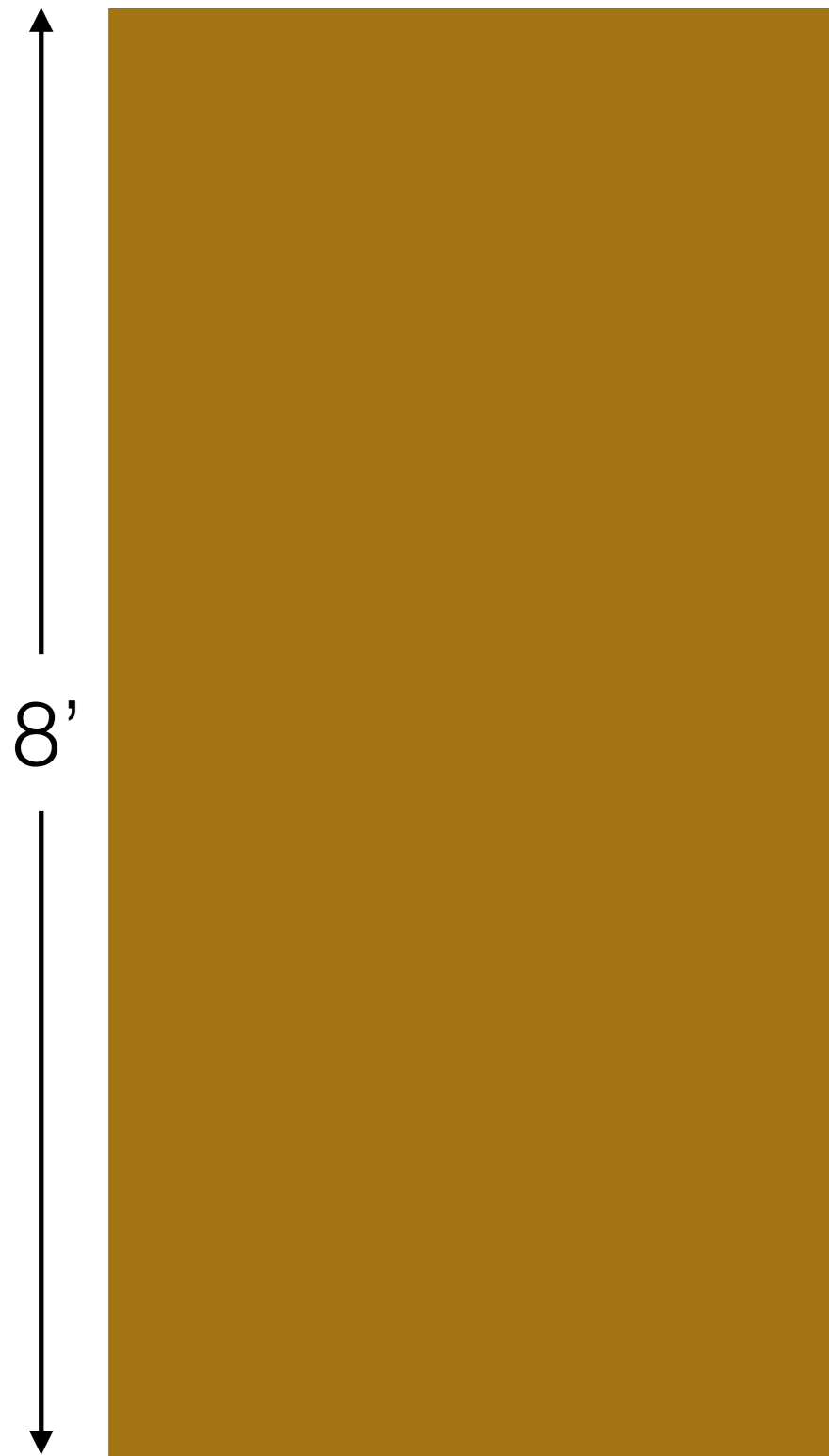

← 3' →
Front

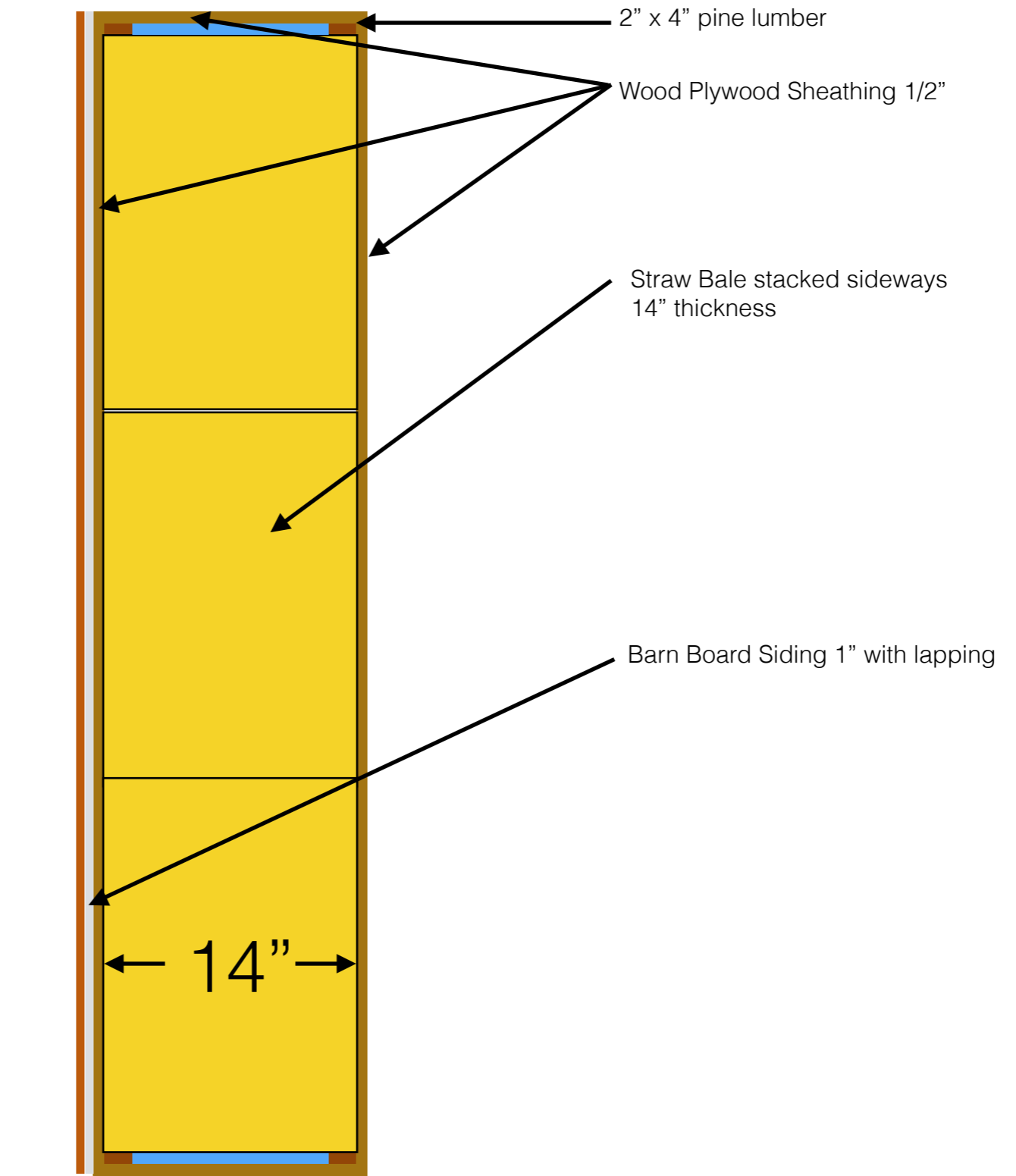

← 16" →
Side Exposed

2" x 4" pine lumber

Wood Plywood Sheathing 1/2"

Straw Bale stacked sideways
14" thickness

Barn Board Siding 1" with lapping

Straw Bale Roofing

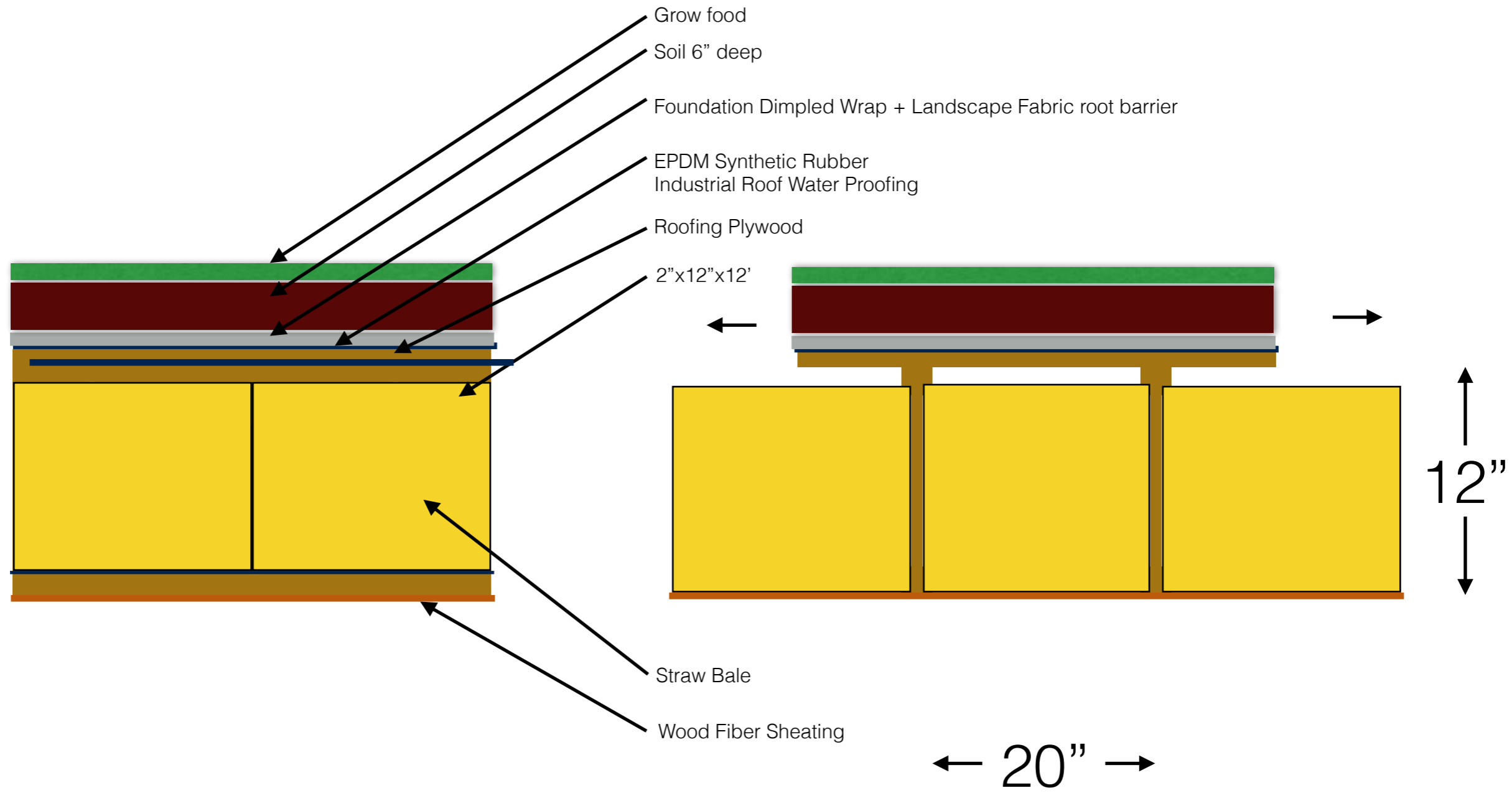

Side Exposed

Front Exposed

Straw Bale Tiny House 2 - Parts List and Cost

Description	Qty	Price	Total
Floor/Ceiling deck - Cedar 2"x12"x16'	4	\$50	\$200
Floor/Ceiling deck - Cedar 2"x12"x10'	4	\$45	\$180
Floor/Ceiling deck - Pine 2"x12"x10'	28	\$40	\$1120
Floor/Roof deck - Plywood 3/4" x 4' x 8'	20	\$70	\$1400
Screws	1	\$50	\$50
Concrete Deck Blocks	12	\$12	\$144
Gravel - 10 cu. yards.	2	\$600	\$1200
Straw Bales (Mono Lea) - small bales	126	\$7	\$882
Floor/Roof deck - Plywood 1/2" x 4' x 8'	10	\$60	\$600
Framing modular boxes 2"x 4" x 8'	48	\$4	\$192
EPDM green roof liner - 15' x 15' -45mil	2	\$560	\$1120
EPDM glue	1	\$80	\$80
Door - main front 36"x80" - with window	1	\$800	\$800
Window - kitchen - 47"x60"	1	\$600	\$600
Slide glass door exterior - 72"x80"	1	\$1500	\$1500
Siding - Barn Board 1" x 8" x 8'	82	\$18	\$1476
Total			\$11544

Energy, Water, Waste - Parts List and Cost

Description	Qty	Price	Total
Solar PV panels (66.9 x39.1 x1.38 in) 340 watts	6	\$350	\$2100
5 kWh Lithium iron phosphate battery	1	\$2800	\$2800
Solar inverter, integrated with an MPPT solar charge, 48V 3000watt controller	1	\$1500	\$1500
			\$0
Tiny wood stove and parts	1	\$2000	\$2000
			\$0
Sun-Mar Composting White High Capacity Non-Electric Toilet	1	\$2000	\$2000
			\$0
IBC for rain water collection	1	\$200	\$200
			\$0
			\$0
			\$0
			\$0
			\$0
			\$0
Total			\$10600